

# Sizing criteria for cylinders and servocylinders

## 1 INTRODUCTION

The choice of the hydraulic cylinder is based upon the system working conditions. The following sections show how to choose the suitable hydraulic cylinder to ensure top performances and to avoid mechanical damages. When high acceleration and/or short cycle times are requested, an analysis performed by the Atos technical office is strongly recommended.

## 2 SYMBOLS, DIAGRAMS AND BASIC FORMULAE

### Single rod cylinders

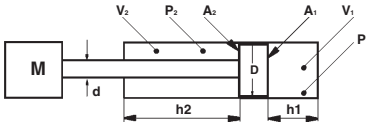

Pushing area  
 $A_1 = \frac{\pi \cdot D^2}{4 \cdot 100} \text{ [cm}^2\text{]}$

Cylinder speed during rod extension  
 $V_1 = \frac{10 \cdot Q}{A_1 \cdot 60} \text{ [m/sec]}$

Force applied during rod extension  
 $F_p = (p_1 \cdot A_1 - p_2 \cdot A_2) \cdot 10 \text{ [N]}$

### Double rod cylinders

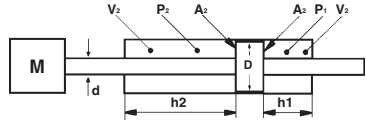

Pushing and pulling area  
 $A_2 = \frac{\pi \cdot (D^2 - d^2)}{4 \cdot 100} \text{ [cm}^2\text{]}$

Cylinder speed during rod extension/retraction  
 $V = \frac{10 \cdot Q}{A_2 \cdot 60} \text{ [m/sec]}$

Force applied during rod extension/retraction  
 $F_p = (p_2 - p_1) \cdot A_2 \cdot 10 \text{ [N]}$

Quantity	Unit	Symbol
Force	N	F
Pressure	bar	p
Section	cm <sup>2</sup>	A
Bore size	mm	D
Rod diameter	mm	d
Cylinder stroke	mm	h
Flow rate	l/min	Q
Speed	m/s	V
Acceleration	m/s <sup>2</sup>	a
Load mass	kg	M

The hydraulic force  $F_p$  has to be upper than the algebraic sum of all the forces acting on the cylinder to ensure the performances requested:

$F_p = F_i + F_f + P$

$F_i = M \cdot a =$  Inertial forces  
 $F_f =$  Friction forces  
 $P =$  Weight (only for vertical loads)

The above formula can be used for the calculation of necessary hydraulic force requested by the particular application.

## 3 SIZING

The table below reports the push/pull sections and forces for three different working pressures. Once the push/pull forces are known, the size of the hydraulic cylinder can be chosen from the table below. The values have been determined using the formulae in section 2.

### PULL FORCE [kN]

Bore [mm]	25		32		40			50			63			80			100			
Rod [mm]	12	18	14	22	18	22	28	22	28	36	28	36	45	36	45	56	45	56	70	
Pull section [cm <sup>2</sup> ]	3,8	2,4	6,5	4,2	10,0	8,8	6,4	15,8	13,5	9,5	25,0	21,0	15,3	40,1	34,4	25,6	62,6	53,9	40,1	
Pull force [kN]	p=100 bar	3,8	2,4	6,5	4,2	10,0	8,8	6,4	15,8	13,5	9,5	25,0	21,0	15,3	40,1	34,4	25,6	62,6	53,9	40,1
	p=160 bar	6,0	3,8	10,4	6,8	16,0	14,0	10,3	25,3	21,6	15,1	40,0	33,6	24,4	64,1	55,0	41,0	100,2	86,3	64,1
	p=250 bar	9,4	5,9	16,3	10,6	25,1	21,9	16	39,6	33,7	23,6	62,5	52,5	38,2	100,2	85,9	64,1	156,6	134,8	100,1

Bore [mm]	125		140		160		180		200		250		320		400			
Rod [mm]	56	70	90	90	70	90	110	110	90	110	140	140	180	180	220	220	280	
Pull section [cm <sup>2</sup> ]	98,1	84,2	59,1	90,3	162,6	137,4	106,0	159,4	250,5	219,1	160,2	336,9	236,4	549,8	424,1	876,5	640,9	
Pull force [kN]	p=100 bar	98,1	84,2	59,1	90,3	162,6	137,4	106,0	159,4	250,5	219,1	160,2	336,9	236,4	549,8	424,1	876,5	640,9
	p=160 bar	156,9	134,8	94,6	144,5	260,1	219,9	169,6	255,1	400,9	350,6	256,4	539,1	378,2	879,6	678,6	1.402,4	1.025,4
	p=250 bar	245,2	210,6	147,8	225,8	406,4	343,6	265,1	398,6	626,4	547,8	400,6	842,3	591,0	1.374,4	1.060,3	2.191,3	1.602,2

### PUSH FORCE [kN]

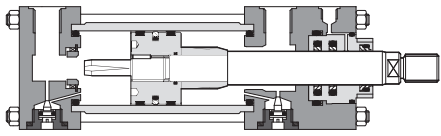
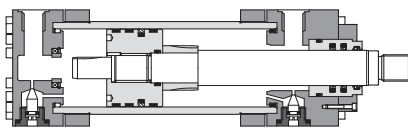
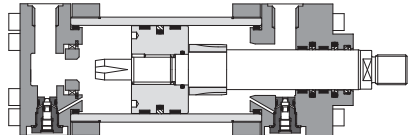
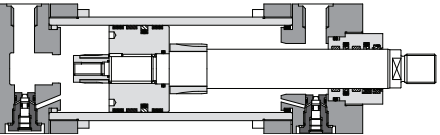

Bore [mm]	25	32	40	50	63	80	100	125	140	160	180	200	250	320	400	
Push section [cm <sup>2</sup> ]	4,9	8,0	12,6	19,6	31,2	50,3	78,5	122,7	153,9	201,1	254,5	314,2	490,9	804,2	1.256,6	
Push force [kN]	p=100 bar	4,9	8,0	12,6	19,6	31,2	50,3	78,5	122,7	153,9	201,1	254,5	314,2	490,9	804,2	1.256,6
	p=160 bar	7,9	12,9	20,1	31,4	49,9	80,4	125,7	196,3	246,3	321,7	407,2	502,7	785,4	1.286,8	2.010,6
	p=250 bar	12,3	20,1	31,4	49,1	77,9	125,7	196,3	306,8	384,8	502,7	636,2	785,4	1.227,2	2.010,6	3.141,6

#### 4 CHOICE OF THE CYLINDER SERIES

<p><b>SERIES CK/CH - tab. B137 - B140 to ISO 6020-2</b></p>  <p>- Nominal pressure <b>16 MPa</b> (160 bar) - max. <b>25 MPa</b> (250 bar)          - Bore sizes from <b>25 to 200 mm</b>          - Rod diameters from <b>12 to 140 mm</b></p>	<p><b>SERIES CH BIG BORE SIZE - tab. B160 to ISO 6020-3</b></p>  <p>- Nominal pressure <b>16 MPa</b> (160 bar) - max. <b>25 MPa</b> (250 bar)          - Bore sizes from <b>250 to 400 mm</b>          - Rod diameters from <b>140 to 220 mm</b></p>
<p><b>SERIES CN - tab. B180 to ISO 6020-1</b></p>  <p>- Nominal pressure <b>16 MPa</b> (160 bar) - max. <b>25 MPa</b> (250 bar)          - Bore sizes from <b>50 to 200 mm</b>          - Rod diameters from <b>28 to 140 mm</b></p>	<p><b>SERIES CC - tab. B241 to ISO 6022</b></p>  <p>- Nominal pressure <b>25 MPa</b> (250 bar) - max. <b>32 MPa</b> (320 bar)          - Bore sizes from <b>50 to 320 mm</b>          - Rod diameters from <b>36 to 220 mm</b></p>

#### 5 CHECK OF THE BUCKLING LOAD

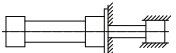
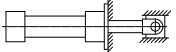
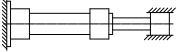
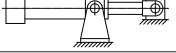
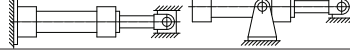
##### 5.1 Calculation of the ideal length

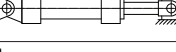
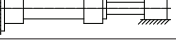
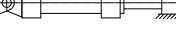
Style	Rod end connection	Type of mounting	Fc
A, E, K, N, T, W, Y, Z	Fixed and rigidly guided		0,5
A, E, K, N, T, W, Y, Z	Pivoted and rigidly guided		0,7
B, P, V	Fixed and rigidly guided		1,0
G	Pivoted and rigidly guided		1,0
B, P, V, L	Pivoted and rigidly guided		1,5
A, E, K, N, T, W, Y, Z	Supported but not rigidly guided		2,0
C, D, H, S	Pivoted and rigidly guided		2,0
B, P, V	Supported but not rigidly guided		4,0
C, D, H, S	Supported but not rigidly guided		4,0

For cylinders working with push loads a buckling load's checking has to be considered before choosing the rod size. This check is performed considering the fully extended cylinder as a bar having the same diameter of the cylinder rod (safety criteria).

See the following indications:

**1.** determine the stroke factor "Fc" depending to the mounting style and to the rod end connection, see table at side

**2.** calculate the "ideal length" from the equation:  
 ideal length = Fc x stroke

If a spacer has been selected, the spacer's length must be added to the stroke

**3.** calculate the push load as indicated in section [3] or using the formulae indicated in section [2]

**4.** obtain the point of intersection between the push force and the ideal length using the rod selection chart 5.2

**5.** the correct rod diameter is readen from the curved line above the point of intersection: if the rod diameter chosen is inferior, another one has to be selected

##### 5.2 Rod selection chart

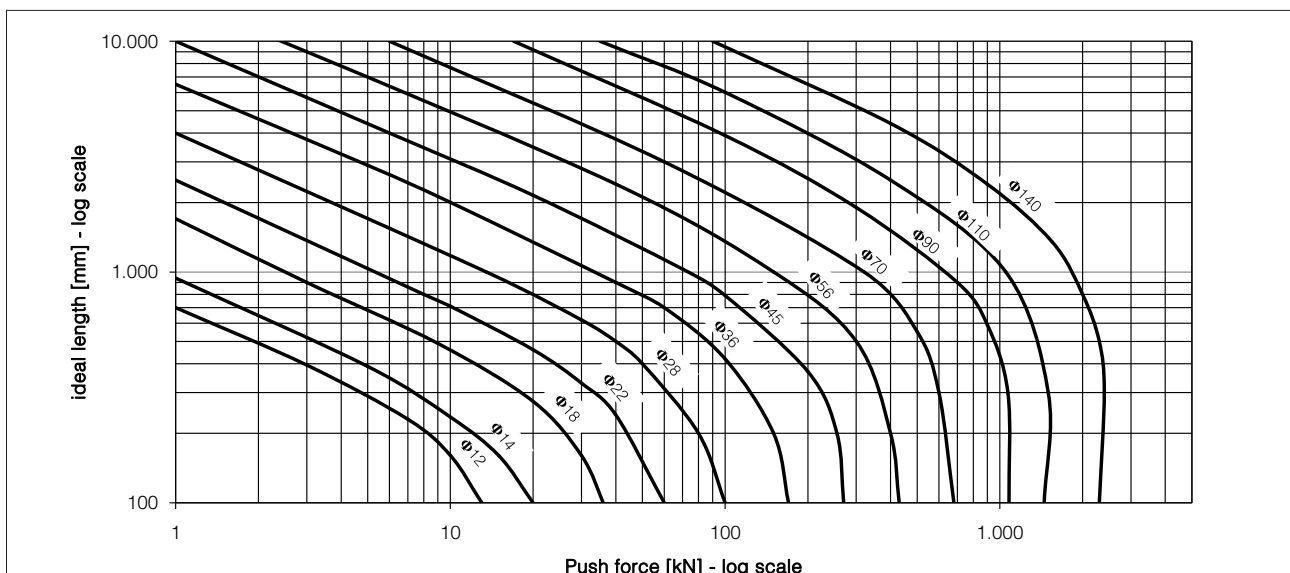

## 6 PREDICTION OF THE EXPECTED CYLINDER'S MECHANICAL WORKING LIFE

The rod thread is the cylinder's max critical part, thus the expected cylinder's working life can be evaluated by the prediction of the expected rod thread fatigue life. The fatigue rod fractures take place suddenly and without any warning, thus it is always recommended to check if the rod is subject to fatigue stress (not necessary if the cylinder works with push loads) and thus if the expected rod threads fatigue life may become an issue in relation to the required cylinder working life. The charts below do not include the rods which are fatigue-free for working pressures over 250 bar. The curves are referred to ideal working conditions and do not take into account misalignments and transversal loads that could decrease the predicted life cycles. The charts are intended valids for all the cylinders and servocylinders series with standard materials and sizes. For the evaluation of the expected fatigue life of rods with "Nickel and chrome plating" (option **K**) and stainless steel rods (CNX series), contact our technical office. For double rod cylinders it is recommended to use the secondary rod only for the compensation of the pushing areas, if this condition is verified the rod fatigue life may be determined by the curves in section 6.2.

### 6.1 Calculation procedure

1. Identify the curve of proper rods fatigue life graph according to the selected bore/rod size. Fatigue-free bore/rod couplings are not included in the graphs.
2. Intersect the working pressure with the curve corresponding to the rod under investigation and determine the expected rod life cycles. If the calculated rod fatigue life is lower than 500.000 cycles a careful analysis of our technical office is suggested.

### 6.2 Rods fatigue life charts

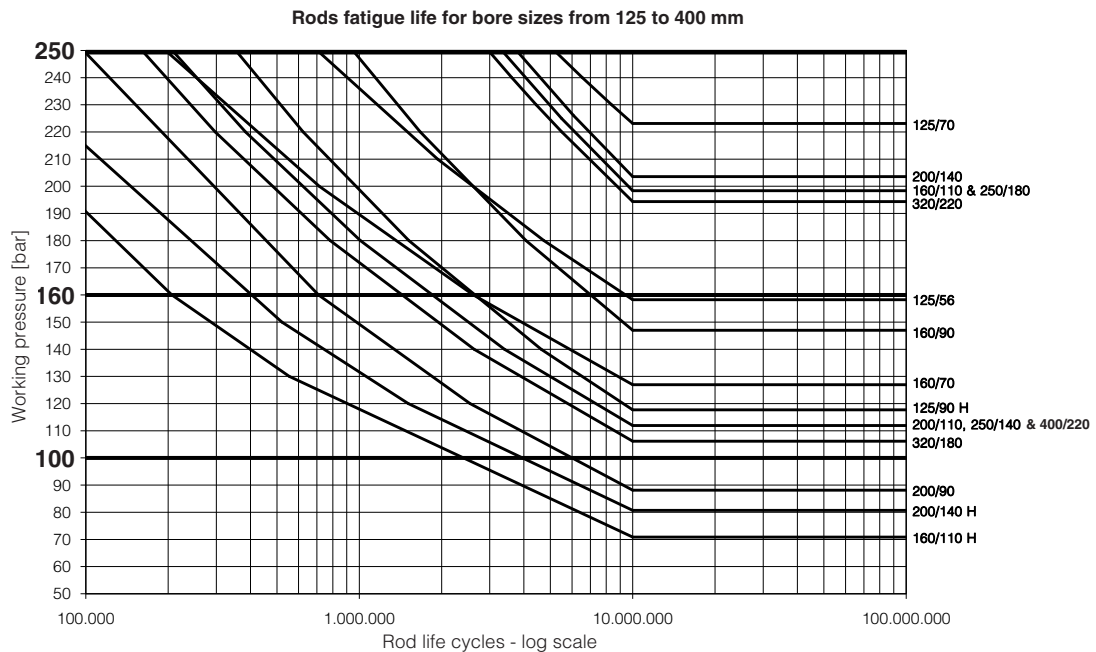
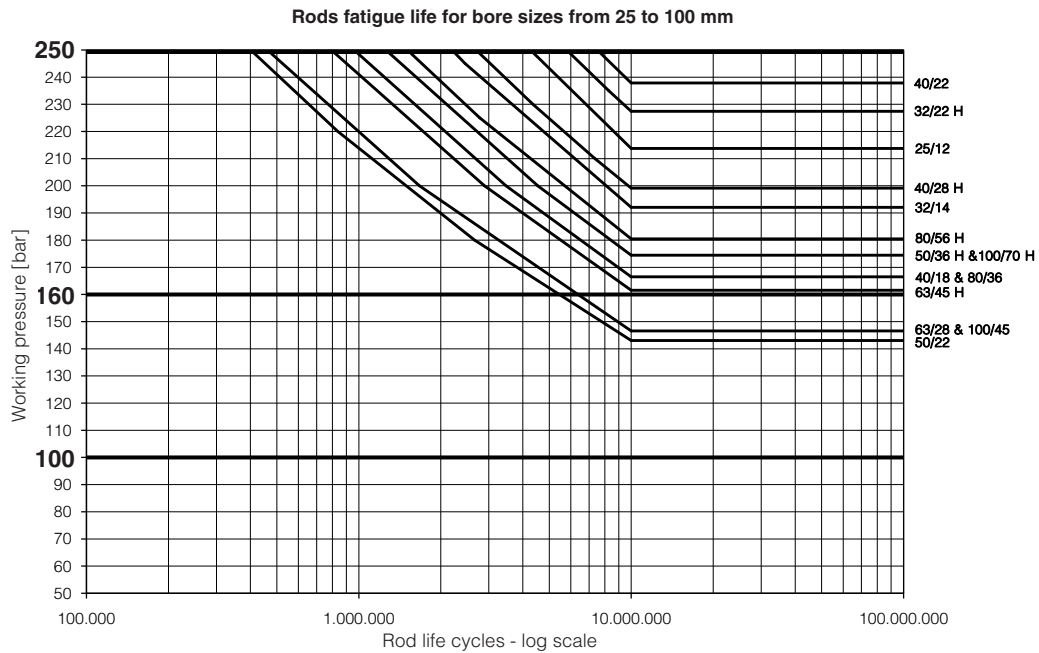

**Note:** the curves are labelled according to the bore/rod size. The light male thread (option **H**) is indicated by the "H" after the rod  
Example: label **125/90 H** means bore = 125 mm, rod = 90 mm and rod with option **H**

## 7 DYNAMIC LIMITS IN THE APPLICATION OF HYDRAULIC CYLINDERS

The calculation of pulsing value  $\omega_0$  of the cylinder-mass system allows to define the minimum acceleration/deceleration time, the max. speed and the min. acceleration/deceleration space to not affect the functional stability of the system.

1. Calculate the system pulsation value  $\omega_0$

$$\omega_0 = \sqrt{\frac{40 \cdot E \cdot A_1}{c \cdot M}} \cdot \frac{1 + \sqrt{\alpha}}{2} \quad \left[ \frac{\text{rad}}{\text{s}} \right]$$

2. Calculate the minimum acceleration time

$$t_{\min} = \frac{35}{\omega_0} \quad [\text{s}]$$

3. Calculate the maximum speed

$$V_{\max} = \frac{S_{\text{tot}}}{t_{\text{tot}} - t_{\min}} \quad [\text{mm/s}] \quad \text{The formula is valid considering a constant acceleration value during } t_{\min}$$

4. Determine the minimum acceleration/deceleration space

$$S_{\min} = \frac{V_{\max} \cdot t_{\min}}{2} \quad [\text{mm}]$$

$\omega_0$ ,  $t_{\min}$ ,  $V_{\max}$  and  $S_{\min}$  values are calculated in conservative way.

## Positioning cycle

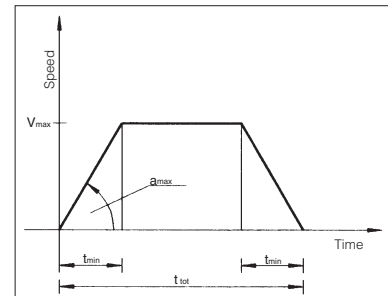

Where:

$E$  = oil modulus of elasticity  $[\text{kg/cm} \cdot \text{s}^2]$

for mineral oil  $E = 1.4 \cdot 10^7 \text{ kg/cm} \cdot \text{s}^2$

$c$  = stroke  $[\text{mm}]$

$M$  = mass  $[\text{kg}]$

$A_1$  = piston section  $[\text{cm}^2]$

$\alpha$  =  $A_2/A_1$  push / pull area ratio

$S_{\text{tot}}$  = total space to run  $[\text{mm}]$

$t_{\text{tot}}$  = total time at disposal  $[\text{s}]$

## 8 CHECK OF THE HYDRAULIC CUSHIONING

Hydraulic cushionings are a kind of "dumpers" designed to dissipate the energy of a mass connected to the rod and directed towards the cylinder stroke-ends, reducing its velocity before the mechanical contact, thus avoiding mechanical shocks that could reduce the average life of the cylinder and of the entire system. Cushionings are recommended in case of rod speeds higher than 0,05 m/s and when the piston makes a full stroke without any external softening system. The hydraulic cushioning acts along a variable length, depending to the cylinder bore, by isolating the oil volume contained inside, identified as "Cushioning chamber". The energy dissipation in the cylinder/mass system is obtained by causing the outflow of the oil volume of the cylinder chamber by means of calibrated orifices.

### 8.1 Functioning features

Cushioning proves to be effective as much as the pressure inside the cushioning chamber gets close to the ideal behaviour described in the diagram at side. The diagram compares the ideal behaviour with Atos typical real pressure profile, achieved by optimizing the design of the profile of the restricted orifices. In this way high performances have been obtained in terms of dissipated energy with great repeatability even with fluid viscosity variations due to temperature or to different types of fluids.

Atos cushionings profile is designed to exploit at the best the whole cushioning stroke and to perform a "soft" cushioning (see figure at side), where the maximum deceleration is limited and kept constant for its full length. When fast or slow adjustable versions are selected, the cylinder is provided with a needle valve, represented in the figure at side, to optimize the cushioning performances; they are recommended for cylinders with high speeds and low inertial loads.

### Pressure in the cushioning chamber

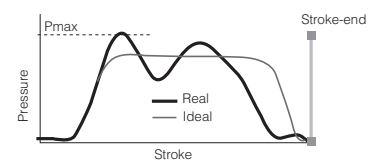

### Speed during cushioning



### 8.2 Application features

The following guidelines refer to CK and CH cylinders: for cylinders CN, CC and CH big bore sizes, contact our technical office. In order to allow the use of cushioning in various applications, three different cushioning versions have been developed:

- slow version, provided with adjustment, for speed  $V \leq 0,5 \cdot V_{\max}$
- fast version, without adjustment, for speed  $V > 0,5 \cdot V_{\max}$
- fast version, provided with adjustment, for speed  $V > 0,5 \cdot V_{\max}$

The maximum permitted speed value  $V_{\max}$  depends to the cylinder size as reported below.

$\varnothing$ Bore [mm]	25	32	40	50	63	80	100	125	160	200
$V_{\max}$ [m/s]	1	1	1	1	0,8	0,8	0,6	0,6	0,5	0,5

### 8.3 Calculation procedure

Check the max energy that can be absorbed by the selected cushioning as follows:

1. calculate the energy to be dissipated  $E$  by the algebraic sum of the kinetic energy  $E_c$  and the potential energy  $E_p$  (for horizontal applications the potential energy is:  $E_p = 0$ )

$$E = E_c + E_p$$

-  $E_c$  (kinetic energy) due to the mass speed

$$E_c = 1/2 \cdot M \cdot V^2 \quad [\text{Joule}]$$

-  $E_p$  (potential energy) due to the gravity and related to the cylinder inclination  $\alpha$  as shown at side

For front cushioning:

$$E_p = -L_f \cdot \frac{M \cdot g \cdot \sin \alpha}{1000} \quad [\text{Joule}]$$

For rear cushioning:

$$E_p = +L_f \cdot \frac{M \cdot g \cdot \sin \alpha}{1000} \quad [\text{Joule}]$$

2. identify the proper cushionings chart in section 8.4 depending to the rod type and to the cushioning side (front or rear). The cushionings charts have been achieved with 250 bar maximum pressure admitted in the cushioning chamber

3. intersect the working pressure with the proper curve depending to the bore/rod size and extract the corresponding  $E_{\max}$  value

4. compare the  $E_{\max}$  value with the energy to be dissipated  $E$  and verify that:

$$E \leq E_{\max}$$

5. for critical applications with high speed and short cushioning strokes an accurate cushioning evaluation is warmly suggested, contact our technical office

## Adjustment screw

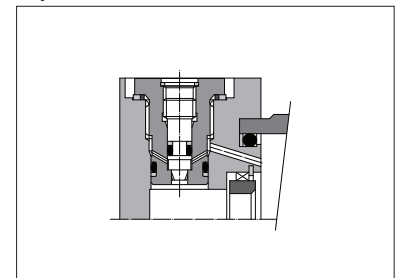

## Symbols

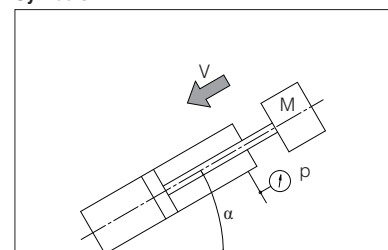

$E$  = energy to be dissipated  $[\text{J}]$

$E_{\max}$  = energy max dissipable  $[\text{J}]$

$M$  = mass  $[\text{kg}]$

$V$  = rod speed  $[\text{m/s}]$

$L_f$  = cushioning length  $[\text{mm}]$

(see section 12 of tables B137, B140)

$g$  = acceleration of gravity  $[\text{m/s}^2]$

consider  $g = 9,81 \text{ m/s}^2$

$\alpha$  = inclination angle  $[\text{°}]$

## 8.4 Cushionings charts

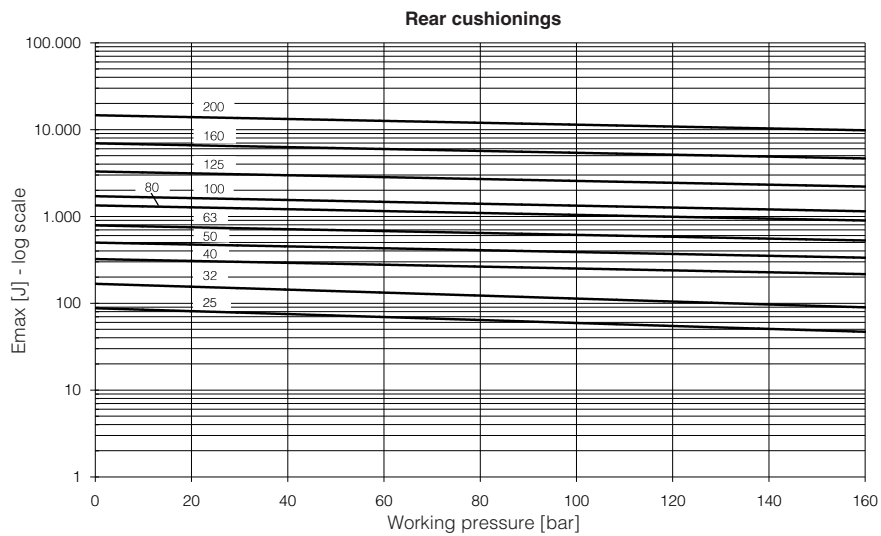
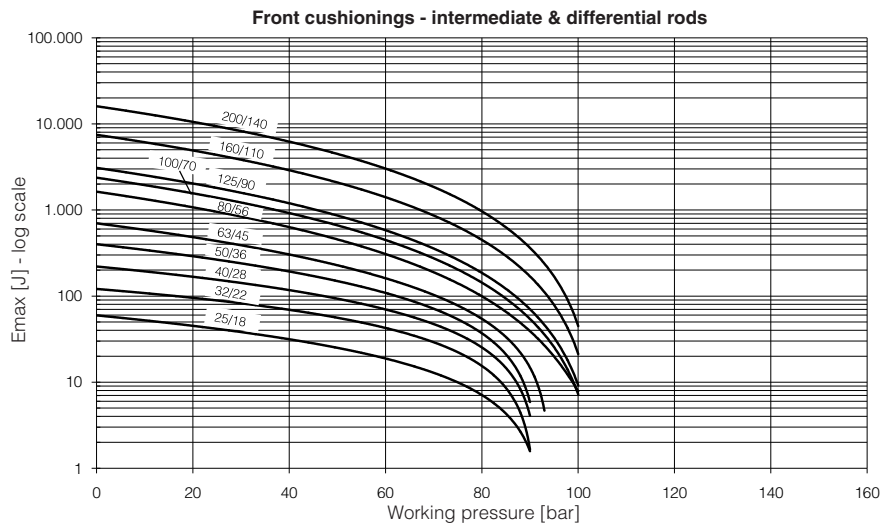
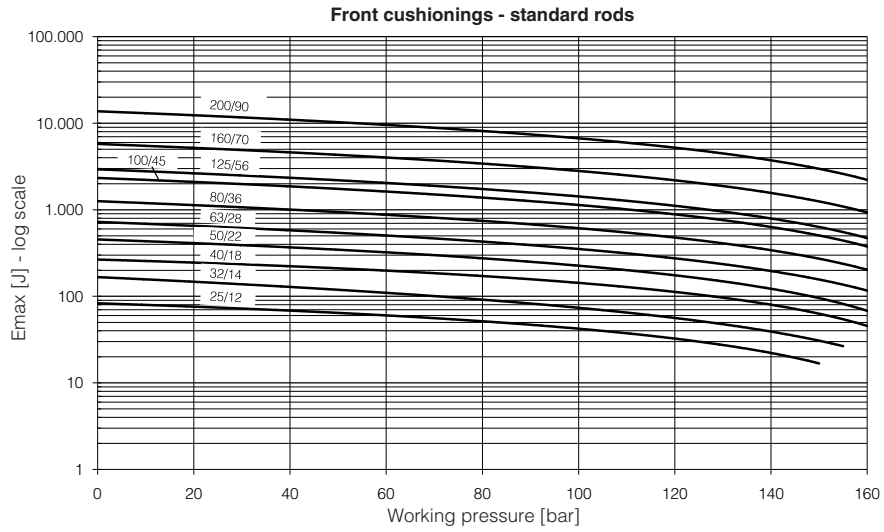

**Notes:**

- the front cushionings graphs are labelled according to the bore/rod size, the rear cushionings graph is labelled according to the bore size
- the curves are intended valid for mineral oil ISO 46: the use of water or water-based fluids can affect the cushioning performance because of high viscosity variations respect to standard mineral oil