

# High flow cartridge valves type SHLI, SHLIR

Directional control, optional poppet seal, ISO 7368 sizes 16-50

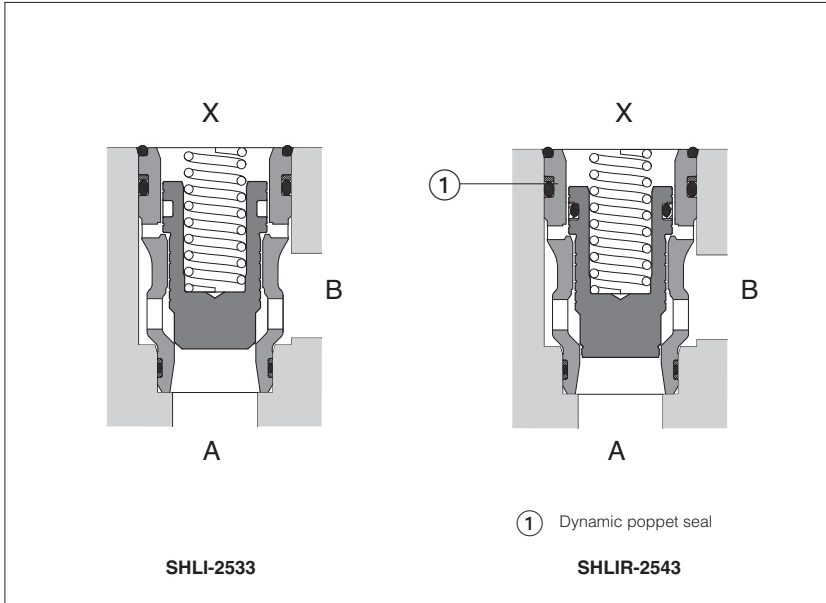

SHLI\* are 2 way cartridge valves, with high flow performances and low pressure drops.

The high flow capability of SHLI\* permits to reduce the cartridge size in comparison with standard SC LI, see section 4 and consequently a reduction of the overall block dimensions.

The recess dimensions conform to ISO 7368 standard.

They can be used with all standard Atos covers to realize directional controls, see tab. H030 and H040.

Two different execution are available:

- SHLI, high flow cartridges without poppet seal.
- SHLIR, as SHLI, but with special LAP dynamic poppet seal to avoid internal leakages from B to X piloting line, for applications requiring improved leak-free feature.

### Technical characteristics

- ISO 7368 sizes from 16 to 50;
- type of poppet: 33 and 43 (with damping nose);
- area ratio (Aa/Ax), see section 2;
- max flow up to 4000 l/min, see section 2;
- max pressure: 350 bar;
- spring cracking pressure: 1, 3 and 6 bar (only 3 and 6 bar for SHLIR).

### Applications

Manifold blocks with high flow performances and reduced dimensions  
SHLIR: circuits with accumulators, safety valve for vertical loads.

### 1 MODEL CODE

<b>SHLI</b>	<b>R</b>	<b>-</b>	<b>16</b>	<b>43</b>	<b>1</b>	<b>**</b>	<b>/*</b>
High flow cartridges according to ISO 7368						Seals material: omit for NBR (mineral oil & water glycol) <b>PE</b> = FPM	
Optional poppet seal (omit if not required)					Serial number		
Size: <b>16 25 32 40 50</b>				Spring cracking pressure: <b>1</b> = 1 bar (not for SHLIR) <b>3</b> = 3 bar <b>6</b> = 6 bar			
				Type of poppet, see section 2 <b>33</b> = without damping nose <b>43</b> = with damping nose			

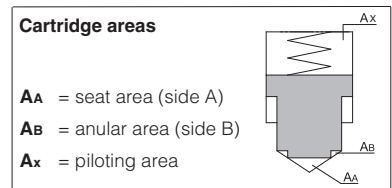

### 2 HYDRAULIC CHARACTERISTICS (based on mineral oil ISO VG 46 at 50 °C)

Size	16		25		32		40		50	
Poppet type	33	43	33	43	33	43	33	43	33	43
Max flow at $\Delta p = 5$ bar	280	250	480	450	950	830	1500	1300	3000	2750
Maximum flow	550	550	1000	1000	1400	1400	2700	2700	4000	4000
Max pressure (ports A, B, X)	350									
Aa	2,14		4,91		8,04		12,57		19,63	
AB (% of Aa)	78		64		72		89		69	
Ax (% of Aa)	178		164		172		189		169	
Pilot volume	2,59	2,97	8,05	8,85	16,6	17,98	38	40,37	66,37	69,68

**3 MAIN CHARACTERISTICS OF HIGH FLOW CARTRIDGES VALVES TYPE SHLI AND SHLIR**

Assembly position / location	Any position
Surface finishing	Roughness index Ra 0,4 - flatness ratio 0,01/100 (ISO 1101)
Ambient temperature	from -20°C to +70°C
Fluid	Hydraulic oil as per DIN 51524 .... 535; for other fluids see section I
Recommended viscosity	15 ÷ 100 mm²/s at 40°C (ISO VG 15 ÷ 100)
Fluid contamination class	ISO 4406 class 21/19/16 NAS 1638 class 10, in line filters of 25 µm (β25 ≥75 recommended)
Fluid temperature	-20°C +60°C (standard seals and water glycol) -20°C +80°C (/PE seals)
Flow direction	B → A or A → B

**4 Q/Δp DIAGRAMS (based on mineral oil ISO VG 46 at 50 °C)**  
High flow SHLI(R) compared with standard SC LI

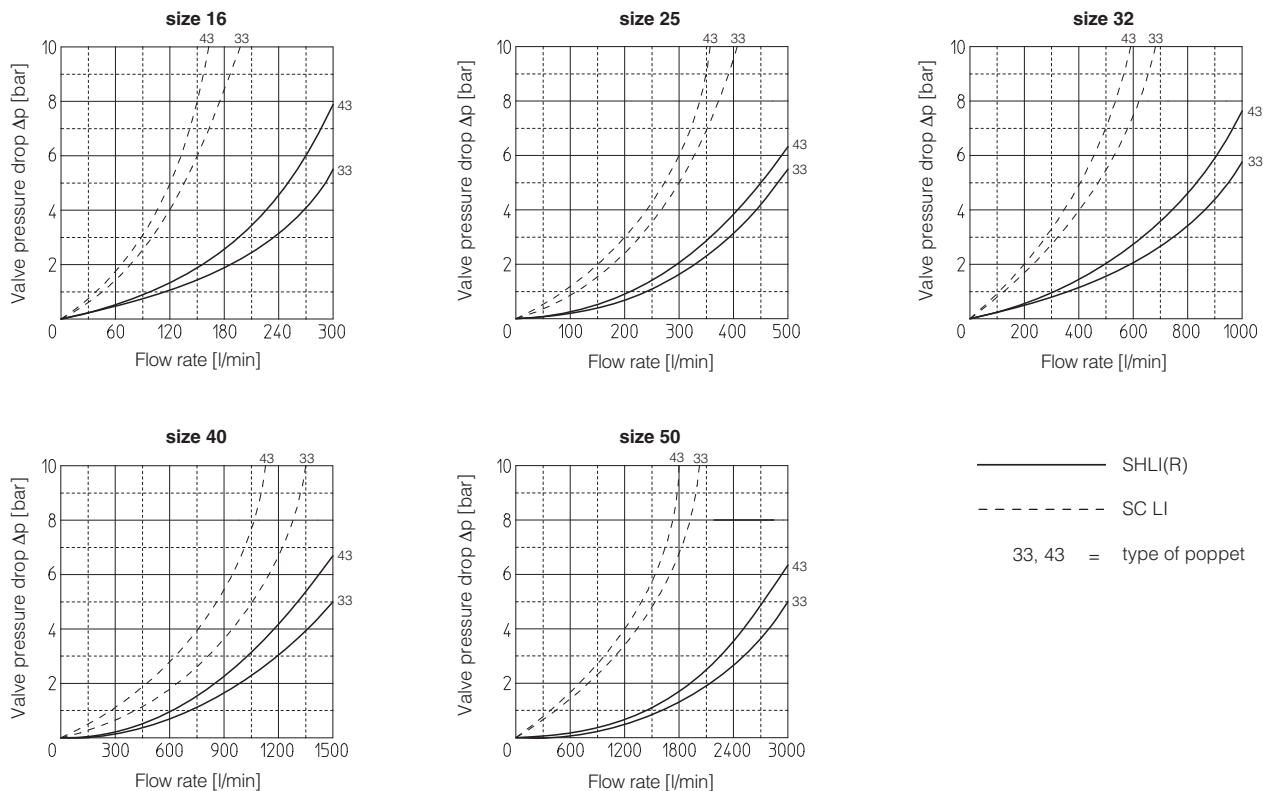

**5 COVER INTERFACE AND RECESS DIMENSIONS [mm]**

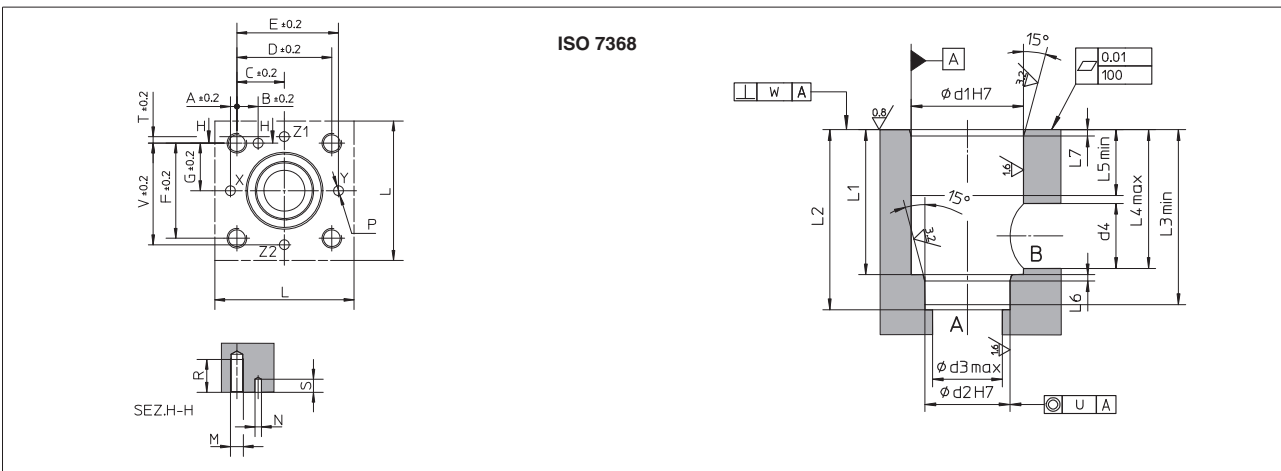

Size	COVER INTERFACE													RECESS												
	A	B	C	D	E	F	G	L	M	∅N	P <sub>max</sub>	R	S <sub>min</sub>	ed1	ed2	ed3	ed4	L1	L2	L3	L4	L5	L6	L7	U	W
16	2	12,5	23	46	48	46	23	65	M8	4	4	20	6	32	25	16	16	43 <sup>+0,1</sup> <sub>0</sub>	56 <sup>+0,1</sup> <sub>0</sub>	54	42,5	20	2	2	0,03	0,05
25	4	13	29	58	62	58	29	85	M12	6	6	30	8	45	34	25	25	58 <sup>+0,1</sup> <sub>0</sub>	72 <sup>+0,1</sup> <sub>0</sub>	70	57	30	2,5	2,5	0,03	0,05
32	6	18	35	70	76	70	35	102	M16	6	8	38	8	60	45	32	32	70 <sup>+0,1</sup> <sub>0</sub>	86 <sup>+0,1</sup> <sub>0</sub>	83	68,5	30	2,5	2,5	0,03	0,1
40	7,5	19,5	42,5	85	92,5	85	42,5	125	M20	6	10	46	8	75	55	40	40	87 <sup>+0,1</sup> <sub>0</sub>	105 <sup>+0,1</sup> <sub>0</sub>	102	84,5	30	3	3	0,05	0,1
50	8	20	50	100	108	100	50	140	M20	8	10	46	8	90	68	50	50	100 <sup>+0,1</sup> <sub>0</sub>	122 <sup>+0,1</sup> <sub>0</sub>	117	97,5	35	3	4	0,05	0,1